

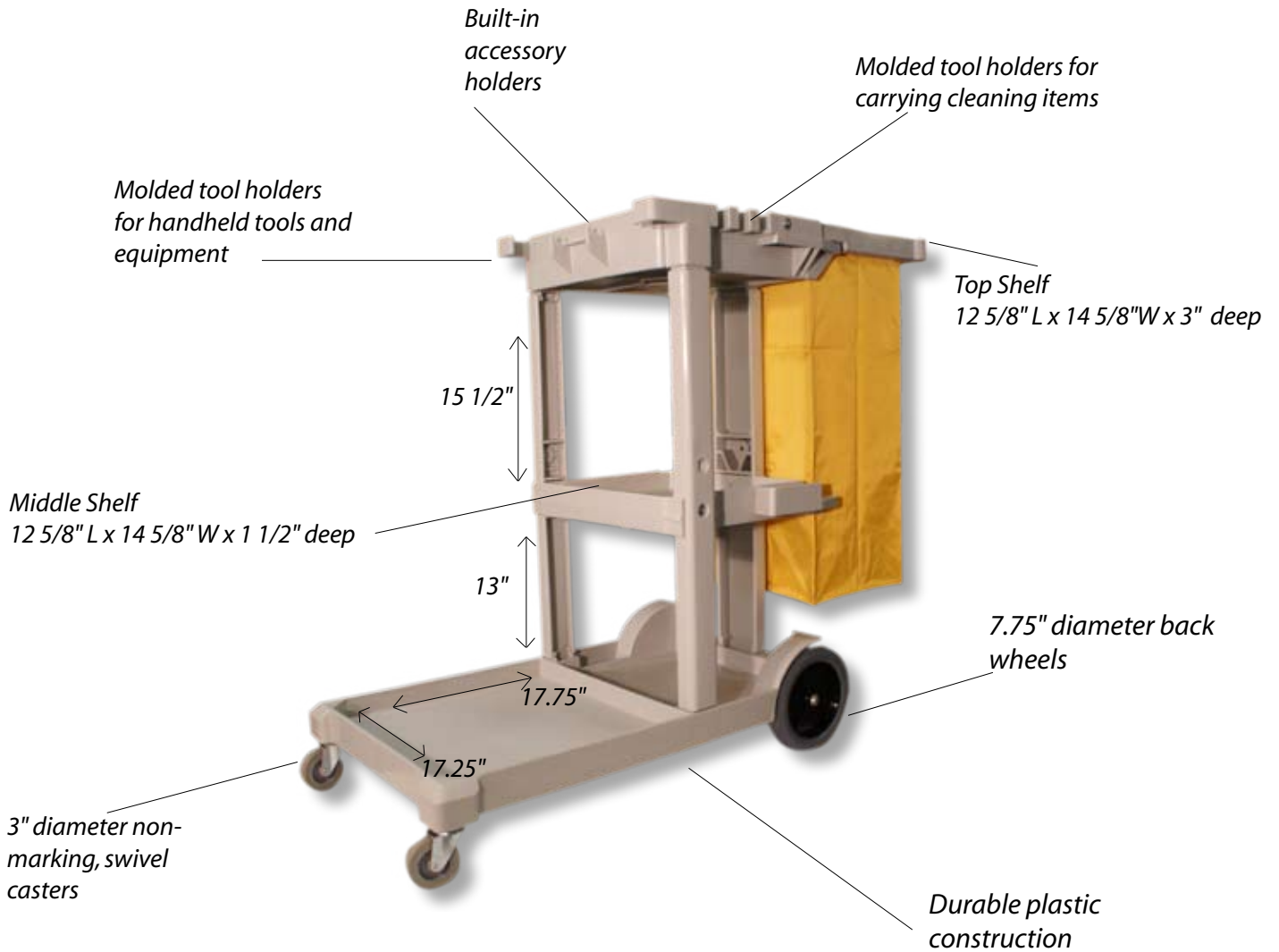

Janitor Cart

Accessories

- Built-in accessory holders
- Non-marking casters
- Durable construction
- 38"H x 29"W x 20"D
- Replacement parts available



Accessories	Item #	Packaging	Shipping Wt. (lbs.)	Cube Size (ft. ³)
Janitor Cart	754002-1	1 Each/Carton	40	4.46
Replacement Wheel	754702-1	1 Each/Carton		
Replacement Rear Wheel	754705-1	1 Each/Carton		
Replacement Bag	754504-1	1 Each/Carton		



PO Box 7444 • Warner Robins GA 31095 478.922.5340
 Quality Assurance Hotline: 800.841.3904 • 9:00 am - 4:00 pm Mon-Fri (EST)
www.odoban.com

527540-081106